



Perforated pan coating technology
TP R TABLET COATER

Coating process technology

TABLET COATERS	CAPACITY		DIMENSIONS				
	Min.(L)	Max.(L)	A	B	C	D	E
Model							
TP Ri5-10	3,5	15	1.620	1.885	1.575	685	890
TP Ri50	7,5	75	2.030	2.045	2.517	1.213	1.304
TP R100	60	150	3.210	2.254	2.838	1.300	1.538
TP R150	90	225	3.210	2.254	3.140	1.465	1.675
TP R200	120	300	3.210	2.321	3.413	1.616	1.798
TP R300	180	450	3.510	2.542	3.975	1.845	2.130
TP R400	240	600	3.510	2.785	4.628	2.105	2.523
TP R500	300	750	3.840	3.050	5.390	2.400	2.990
TP R600	360	900	3.840	3.340	6.275	2.730	3.545

* Approximate data / Loading levels may change depending on tablet's shape and density

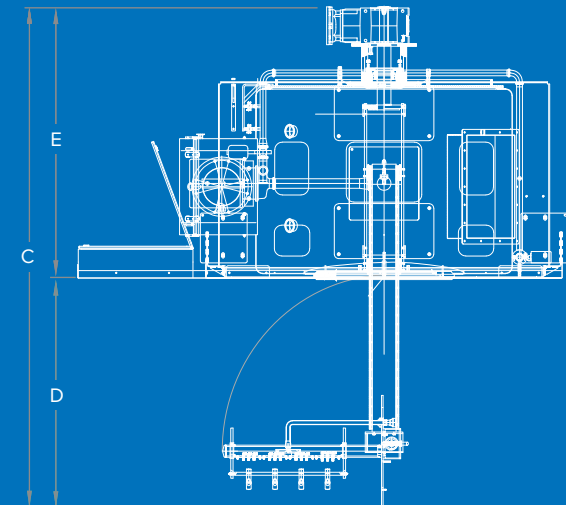
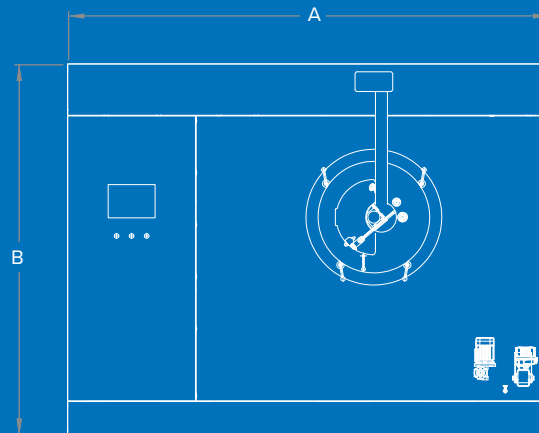

Optionals

- Automatic tablet unloading system
- Nozzle blockage detection system with automatic self-cleaning
- Desiccant wheel system for extra dehumidification
- Coating suspension preparation tank (configurable)
- Containment execution
- Automatic sampling group
- Central WIP unit
- Electropolish
- 21 CFR part 11
- ATEX rated

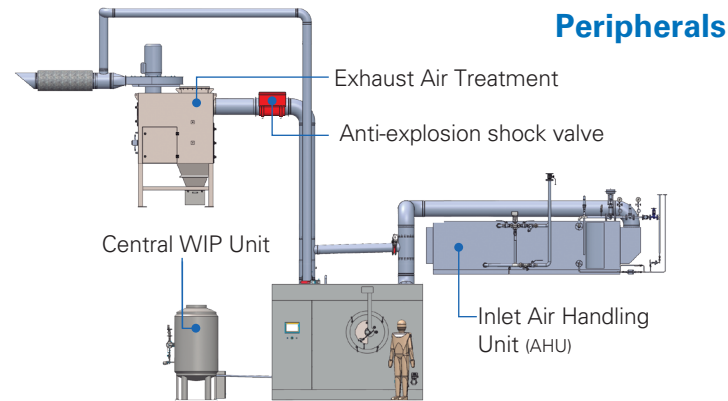

Global Service

Our qualified Romaco Service is globally available for you.

Remote Connection as standard feature assist you as alternative to long-distance travel.



Also in our portfolio

Romaco Tecpharm TP R Optima Tablet Coater

TP R Optima is a smart table coating from 10% to 100% with one single machine based on perforated pan technology. In wall design to be integrated in the clean room to optimize the space for the operations.



Romaco Tecpharm Tablet Coater

TP R Tablet Coater is a film coating machine based on perforated pan technology for tablets and pellets. Its high technology allows an automatic adjustment control of the flow, avoiding the damp, saving coating suspension and optimizing the process time. Innovative high quality equipments certified by accredited entities.

Main Features

- In-Wall design concept.
- Built in AISI 316L, with surfaces in contact with the product mirror polished with roughness Ra <0.5.
- Fully automatic parameter setting.
- Intuitive HMI with Manual and Automatic modes.
- Detachable deflectors.
- Central transmission with direct coupling.
- Schlick® spray nozzles.
- All speed adjustments by frequency inverter.
- Remote connection as standard feature
- Automatic devices for the loading / unloading

Air Treatments

INLET

- Prefiltration with stage G4 and F9
- HEPA 13 absolute filtration
- Dehumidification battery by cold water
- Heating battery by steam
- Drive fan adjustable by frequency inverter
- ΔP monitoring during the process

EXHAUST

- Primary stage filtration
- HEPA 13 absolute filtration
- Cleaning filters by blowing system
- Anti-explosion panel and shock valve
- ΔP monitoring during the process

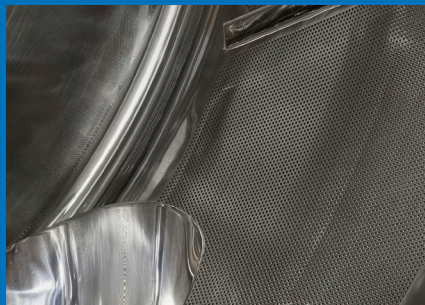

Perforated pan



Rotating arm



Load cells system